

*Enabling Nanoscale Advances*



# Park NX-TSH

The automated Atomic Force Microscopy (AFM) system for ultra large and heavy flat panel displays at nanoscale





# Park NX-TSH

The industry's only automated Tip Scan Head for analyzing samples larger than 300 mm.

## Designed for OLED, LCD and other large sample analysis

- Park Systems has scaled up its AFM tools for Gen8+ and all large flat panel displays with the Park NX-TSH (Tip Scanning Head) system
- Park NX-TSH is designed for large and heavy flat panel display glass and 2D encoders, with integrated micro probe stations for conductive AFM and electric defect analysis
- Park NX-TSH can scan up to 100  $\mu\text{m}$  x 100  $\mu\text{m}$  (x-y direction) and 15  $\mu\text{m}$  (z direction)
- Park NX-TSH has a flexible chuck to accommodate large and heavy samples bigger than 300 mm engineered for OLED, LCD and other large sample analysis



Please scan for more information about the NX-TSH system

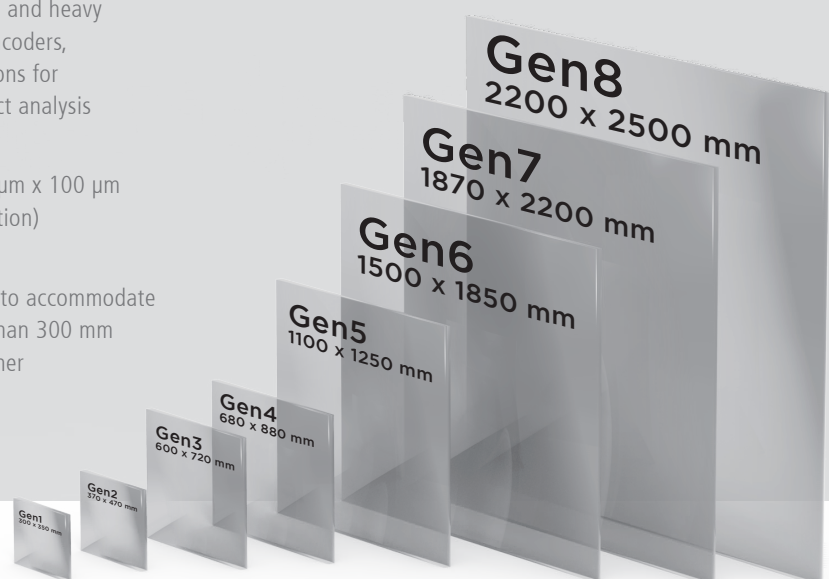

## Fully Automated Tip Scanning Head System using conductive AFM

- The sample is fixed on a sample chuck, and the tip scanning head attached to the gantry moves to the desired measurement positions on the surface sample
- The Park NX-TSH tip scanning head system therefore overcomes the limitations of sample size and weight since the sample is fixed on the sample chuck
- Park NX-TSH was developed specifically for manufacturers setting up fabs that produce next-generation flat panel displays with the objective of overcoming the 300 mm threshold limit
- Using conductive AFM, Park NX-TSH can measure the sample surface with optional probe stations that contact the sample surface and provide current into devices on the wafer:

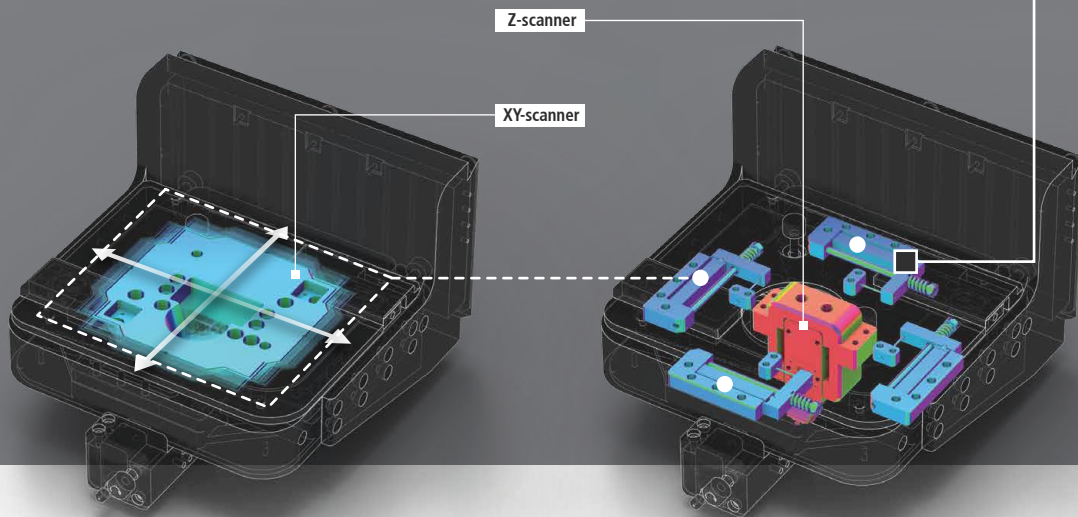
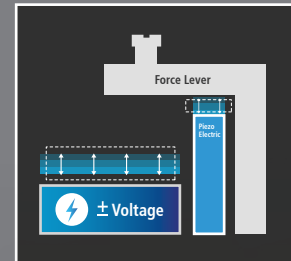

## The Most Accurate, Reliable and Non-Destructive method for Large sample Analysis

As AFM metrology demand for larger flat panel displays increases, Park NX-TSH overcomes nanometrology challenges of large and heavy samples with the Tip Scanning Head and a gantry style air-bearing stage.

### Produces high resolution images and data on:

- surface roughness
- step height
- critical dimension
- sidewall measurements



## Atomic force microscopy is the most accurate, and non-destructive, method of measuring samples at nanoscale

- With Park NX-TSH, reliable, high resolution AFM images can be obtained on OLEDs, LCDs, photomasks and more, using a proprietary gantry style bridge system – improving productivity and quality
- With Park NX-TSH you will get the images and metrology data you need for large and heavy samples such as flat panel display glass and 2D encoders

## Park NX-TSH AFM Technology

### Industry Leading Low Noise Z Detector

Our AFMs are equipped with the most effective low noise Z detectors in the field, with a noise of 0.02 nm over large bandwidth. This produces highly accurate sample topography, no edge overshoot and no need for calibration. Just one of the many ways Park NX-TSH saves you time and gives you better data.

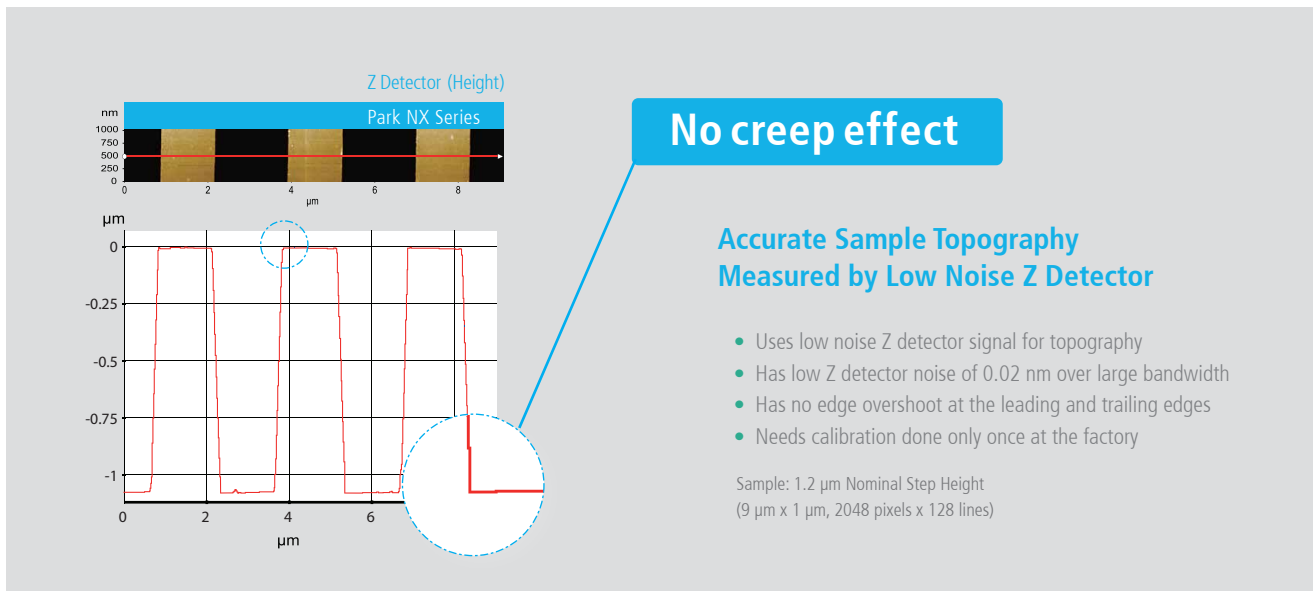

### No artifacts by AFM scanner in low noise closed-loop topography



- Uses low noise Z detector signal for topography
- Has no edge overshoot at the leading and trailing edges
- Needs calibration at the factory and maintenance purpose only

# True Non-Contact™ Mode

True Non-Contact™ Mode is a scan mode unique to Park AFM systems that produces high resolution and accurate data by preventing destructive tip-sample interaction during a scan.

## Accurate Feedback by Faster Z-servo enables True Non-Contact AFM

- Less tip wear → Prolonged high-resolution scan
- Non-destructive tip-sample interaction → Minimized sample modification
- Maintains non-contact scan over a wide range of samples and conditions

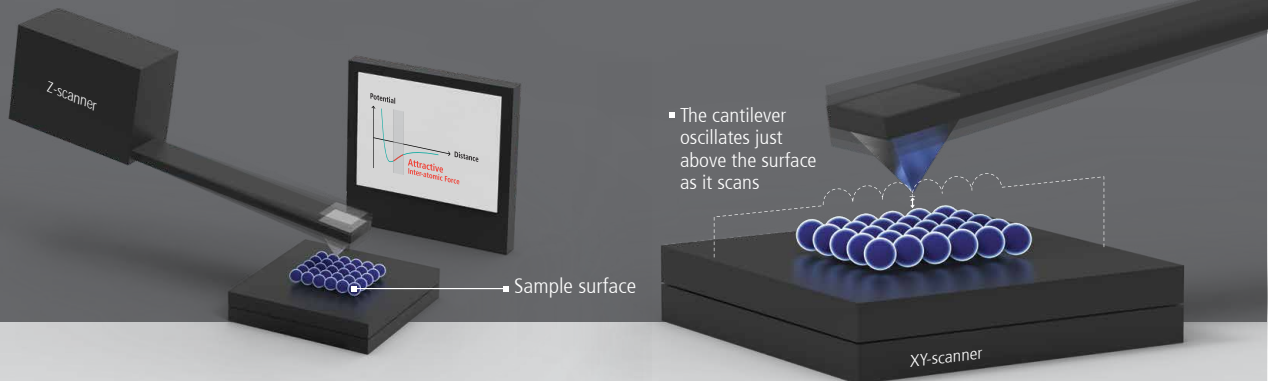
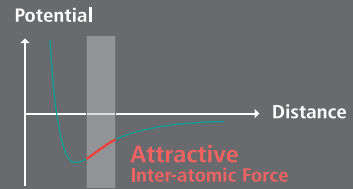

Unlike in contact mode, where the tip contacts the sample continuously during a scan, or in tapping mode, where the tip touches the sample periodically, a tip used in non-contact mode does not touch the sample. Because of this, use of non-contact mode has several key advantages. Scanning at the highest resolution throughout imaging is now possible as the tip's sharpness is maintained. Non-contact mode avoids damaging soft samples as the tip and sample surface avoid direct contact.

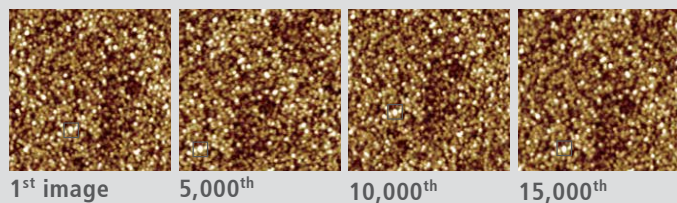
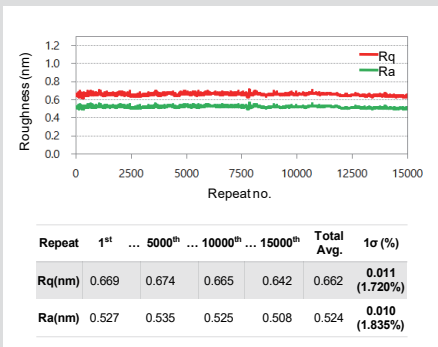

Furthermore, non-contact mode senses tip-sample interactions occurring all around the tip. Forces occurring laterally to tip approach to the sample are detected. Therefore, tips used in non-contact mode can avoid crashing into tall structures that may suddenly appear on a sample surface. Contact and tapping modes only detect the force coming from below the tip and are vulnerable to such crashes.

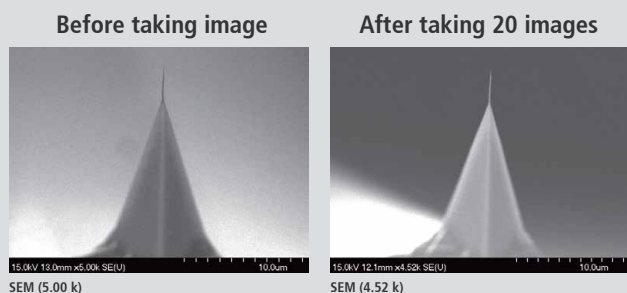
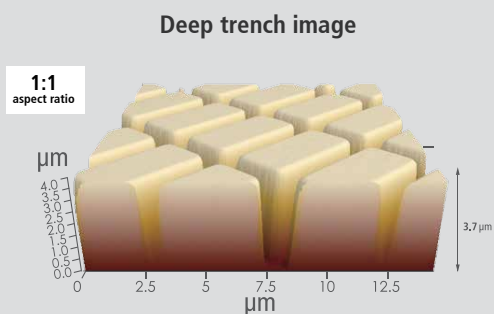

# Park NX-TSH

The most innovative AFM technology  
in one powerful package

## 100 $\mu\text{m}$ x 100 $\mu\text{m}$ Flexure-Guided XY Scanner with Closed-loop Control

The XY scanner consists of symmetrical 2-dimensional flexure and high-force piezoelectric stacks that provide highly orthogonal movement with minimal out-of-plane motion, as well as the high responsiveness essential for precise sample scanning at the nanometer scale.

## 15 $\mu\text{m}$ High Speed Z Scanner with Low Noise Position Sensor

The NX-TSH provides you with unprecedented accuracy in topography height measurement by utilizing its ultra-low noise Z detector instead of the commonly used Z voltage signal that is non-linear in nature. This industry leading low noise Z detector replaces the applied Z voltage as the topography signal.

## Automatic Tip Exchanger (ATX)

The ATX automatically locates tips by pattern recognition and uses a novel magnetic approach to disengage a used tip and pick up a new tip. The laser spot is then automatically aligned by motorized positioning technique.

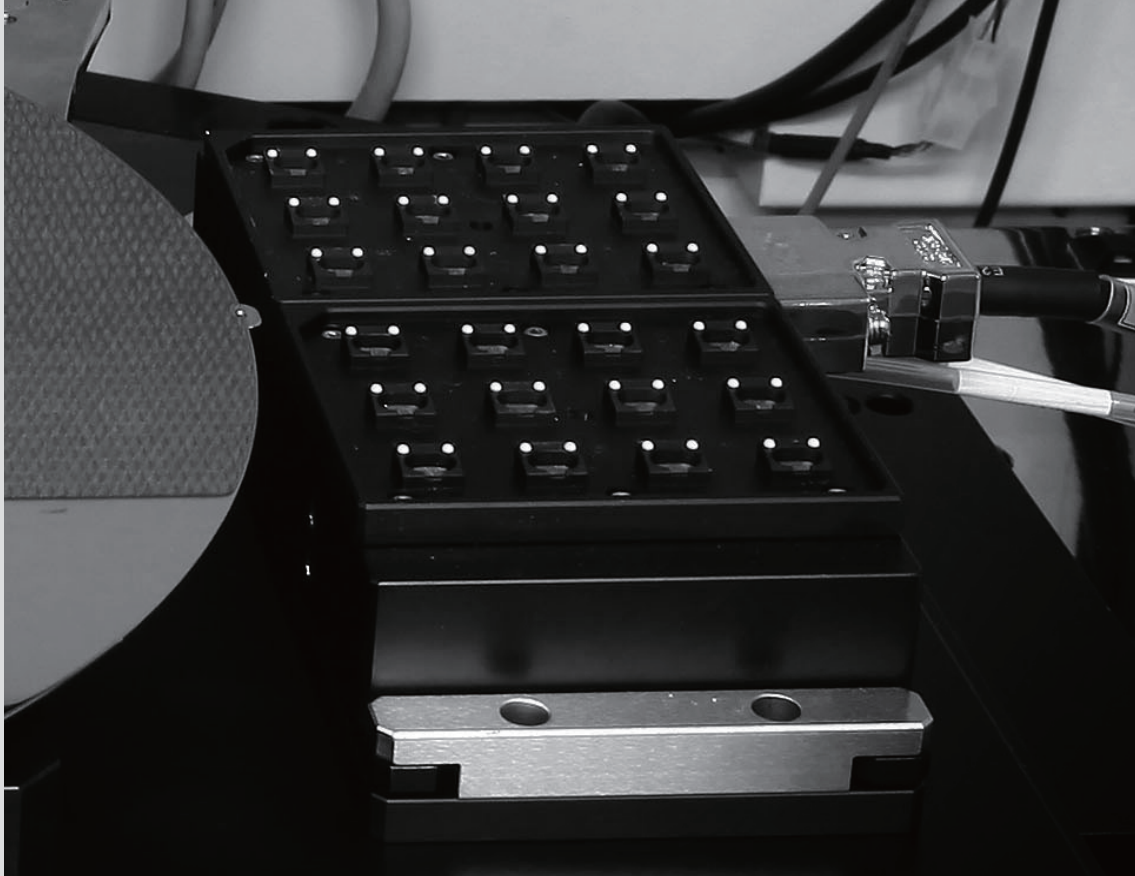

## Automatic Measurement Control so you can get accurate scans with less work

The NX-TSH is equipped with automated software that makes operation nearly effortless. Just select the desired measurement program to get precise multi-site analysis with optimized settings for cantilever tuning, scan rate, gain, and set point parameters.

Park's user-friendly software interface gives you the flexibility to create customized operation routines so you can access the full power of the NX-TSH and get the measurements you need.

Creating new routines is easy. It takes about 10 minutes to make one from scratch, or less than five minutes to modify an existing one.

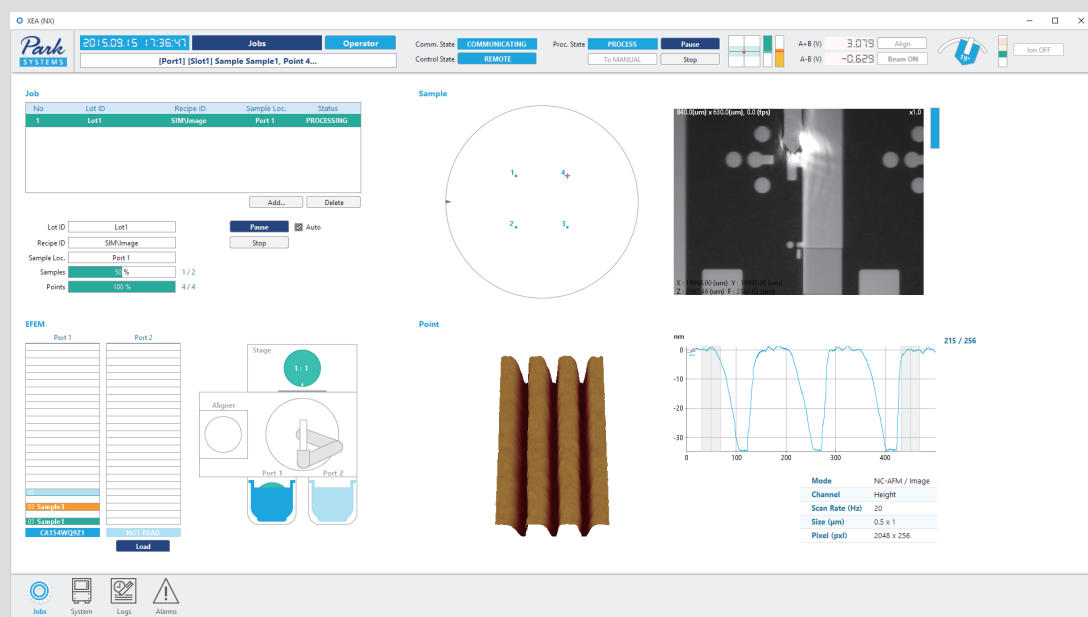

## Ionization System for a more stable scanning environment

Our innovative ionization system quickly and effectively removes electrostatic charges in your sample's environment. Since the system always generates and maintains the ideal balance of positive and negative ions, it can create an extremely stable charge environment with little contamination of the surrounding area and minimal risk of accidental electrostatic charge during sample handling.

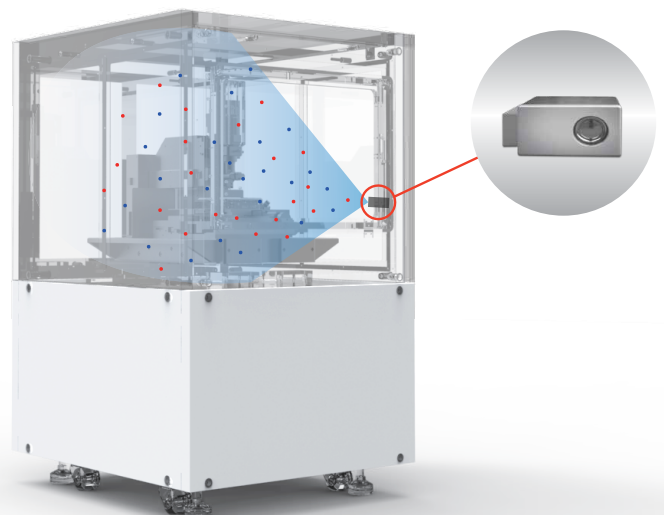

**SPECIFICATION** \* This specification is customizable. Please consult with Park Systems for more information.

System Specification	Sample Size *	Motorized X Stage *	Motorized Y Stage *	Motorized Z Stage *	Motorized Focus Stage *	COGNEX Pattern Recognition	
	520 mm x 520 mm x 12 mm, 10 kg	travels up to 625 mm, ± 3 µm resolution	travels up to 525 mm, ± 3 µm resolution	15 mm Z travel distance, 0.08 µm resolution, < 1 µm repeatability	9 mm Z travel distance for on-axis optics	pattern align resolution of 1/4 pixel	
Scanner Performances	XY Range	XY Resolution	Z Range	Z Resolution	AFM and XY Stage Control Electronics	ADC	DAC
	100 µm × 100 µm	0.15 nm	15 µm	0.016 nm		18 channels 4 high-speed ADC channels 24-bit ADCs for X, Y and Z position sensor	12 channels 2 high-speed DAC channels 20-bit DACs for X, Y and Z positioning
Compliances	Facility Requirements	Room Temperature (Stand By)	Room Temperature (Operating)	Humidity	Floor Vibration Level	Acoustic Noise	
CE SEMI Standard S2/S8		10 °C ~ 40 °C	18 °C ~ 24 °C	30% to 60% (not condensing)	VC-D (6 µm/sec)	Below 65 dB	
	Pneumatics	Power Supply Rating	Total Power Consumption	Ground Resistance			
	Vacuum : -80 kPa CDA (or N <sub>2</sub> ): 0.7 Mpa	208V - 240 V, single phase, 17 A (max)	Consult Park Systems	Below 100 ohms			

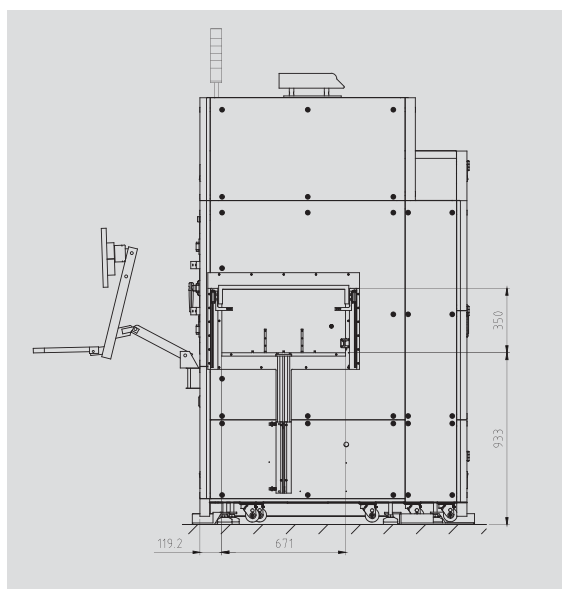
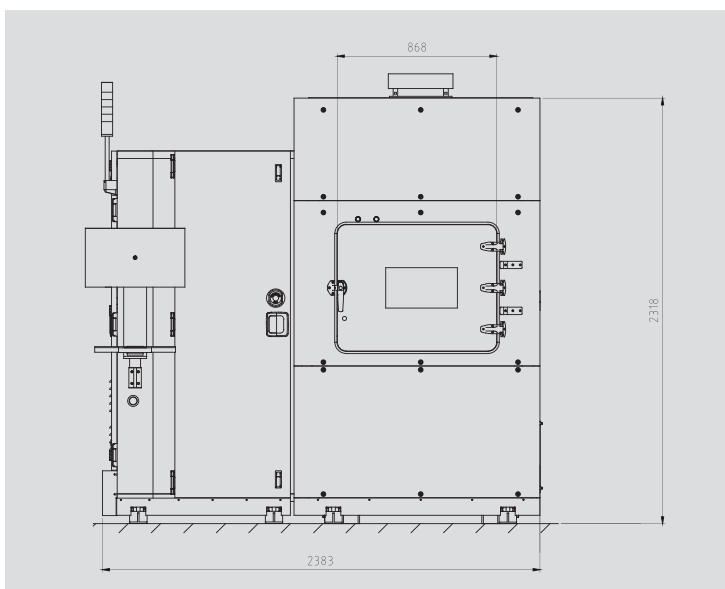

## Committed to contributing to impactful science and technology

Park Systems Corporation is a leading manufacturer of nanoscale microscopy and metrology solutions that encompasses the atomic force microscopy, white light interferometry, infrared spectroscopy and ellipsometry systems. Its products are widely used for scientific research, nanoscale engineering, and semiconductor fabrication and quality assurance. Park Systems provides a full range of AFM products from desktop to fully automated systems with integrated robotic arms. Furthermore, its product line includes WLI AFM, Photo-induced Force Microscopy spectroscopy and ellipsometry systems for those in the chemistry, materials, physics, life sciences, and semiconductor industries. In 2022, Park Systems acquired and merged Accurion GmbH, a leader in high-end ellipsometry and active vibration isolation, to form Park Systems GmbH, Accurion Division.

Park Systems is a publicly traded corporation on the Korea Stock Exchange (KOSDAQ) with corporate headquarters in Suwon, Korea, and regional headquarters in Santa Clara, California, Mannheim, Germany, Paris, France, Beijing, China, Tokyo, Japan, Singapore, India, and Mexico. To learn more, please visit [www.parksystems.com](http://www.parksystems.com).

### Park Systems Americas

+1-408-986-1110 (USA)  
+52-55-7100-2354 (Mexico)

### Park Systems Europe

+49 (0)-621-490896-50 (Germany)  
+33 (0)-6-07-10-87-36 (France)  
+44 (0)-115-784-0046 (UK&Ireland)

### Park Systems GmbH - Accurion

+49-551-999600 (Germany)

### Park Systems Japan

+81-3-3219-1001 (Japan)

### Park Systems Greater China

+86-10-6254-4360 (China)  
+886-3-5601189 (Taiwan)

### Park Systems SE Asia

+65-6634-7470 (Singapore)

### Park Systems Korea

+82-31-546-6800 (Republic of Korea)

### Park Systems India

+91-96869 51464 (India)

### Park Systems Corporate Headquarters

To learn more about Park Systems, please visit [www.parksystems.com](http://www.parksystems.com) or e-mail [inquiry@parksystems.com](mailto:inquiry@parksystems.com)

KANC 15F, Gwanggyo-ro 109, Suwon 16229, Korea Tel. +82-31-546-6800  
©2023 Park Systems Corp. All rights reserved. All products and features are subject to change.  
All brand names and logos are trademarks of their respective companies.  
No part of this publication may be reproduced or distributed without the express written permission of Park Systems Corp.

